

ARTEX C406-2 EMERGENCY LOCATOR TRANSMITTER SYSTEM - MAINTENANCE PRACTICES

1. General

- A. This section contains information required to complete maintenance procedures on the Artex C406-2 Emergency Locator Transmitter (ELT) System.
- B. The Artex C406-2 ELT is found under an aft cargo floor panel that is marked by a location placard.

2. Emergency Locator Transmitter (ELT) Removal/Installation

- A. Remove the Emergency Locator Transmitter (ELT) (Refer to Figure 201).
 - (1) Make sure the battery switch is in the OFF position.
 - (2) Disengage the ELT/NAV circuit breaker on the cockpit circuit breaker panel.
 - (3) Open the aft baggage compartment access door.
 - (4) Remove the aft cargo floor panel between FS 264.00 and FS 307.91 for the 208 and FS 332.00 and FS 355.91 for the 208B.
 - (5) Make sure the ON/OFF switch on the ELT is in the OFF position.
 - (6) Disconnect the coax connectors (PZ121 and PZ123) from the ELT.
 - (7) Loosen the knurled nuts on the mounting tray end cap.
 - (8) Pull the front cover away from the transmitter and mounting tray.
 - (9) Remove the top cover from the transmitter.
 - (10) Pull the mounting tray end cap away from the ELT to disconnect the connector (PZ117) from the ELT.
 - (11) Lift up on the connector end of the ELT to remove it from the mounting tray.
 - (12) Remove the screws that attach the mounting tray to the shelf assembly.
 - (13) Remove the ELT system components from the airplane.
- B. Install the Emergency Locator Transmitter (ELT) (Refer to Figure 201).
 - (1) Use the screws to attach the mounting tray to the support assembly.
 - (2) Put the ELT in the mounting tray at an angle to engage the lock mechanism at the opposite end of the ELT.
 - (3) Push the ELT down into the mounting tray until it is fully installed in the tray.
 - (4) install the top cover onthe ELT transmitter
 - (5) Put the mounting tray end cap onto the mounting tray and ELT to engage the electrical connector (PZ117) on the ELT.
 - (6) Connect the coax connectors (PZ121 and PZ123) to the ELT.
 - (7) Tighten the knurled nuts that hold the ELT in position in the mounting tray.
 - (8) Make sure the ON/OFF switch on the ELT is in the ON position.
 - (9) Engage the ELT/NAV circuit breaker on the cockpit circuit breaker panel.
 - (10) Do a Transmitter Test of the ARTEX C406-2 Emergency Locator Transmitter (ELT) System. Refer to Emergency Equipment - Inspection/Check.
 - (11) Install the aft cargo floor panel between FS 264.00 and FS 307.91 for the 208 and FS 332.00 and FS 355.91 for the 208B.
 - (12) Close the aft baggage compartment door.

3. ELT Antenna Removal/Installation

- A. Remove the ELT Antenna (Refer to Figure 201).

NOTE: The ELT antenna is found on the top surface of the fuselage at FS 292.44 and RBL 15.55 for the Model 208. For the Model 208B, the antenna is at FS 340.44 and RBL 15.55.

- (1) Open the aft baggage compartment door.
- (2) Remove the aft cargo floor panel between FS 264.00 and FS 307.91 for the 208 and FS 332.00 and FS 355.91 for the 208B.
- (3) Make sure the ON/OFF switch on the ELT is in the OFF position.
- (4) Remove the overhead panel directly under the ELT antenna.

- (5) Put the master switch on the emergency locator transmitter in the OFF position.
- (6) Get access to the ELT antenna. Remove the overhead panel directly under the antenna.
- (7) Disconnect the coax connectors (PZ122 and PZ124) from the ELT antenna.
- (8) Remove the screws that attach the ELT antenna to the top surface of the fuselage.
- (9) Remove the antenna from the airplane.

B. Install the ELT Antenna (Refer to Figure 201).

- (1) Make sure that you remove all of the old sealant from the ELT antenna and from the airplane skin. Refer to Chapter 20, Fuel, Weather, Pressure and High Temperature Sealing - Maintenance Practices.
- (2) Connect the coax connectors (PZ122 and PZ124) to the ELT antenna.

NOTE: The coax connector with the 90-degree connector (PZ122) is to be attached to the forward connector.

- (3) Apply a chemically conductive chemical film treatment to the faying surfaces of the ELT antenna and the airplane structure to make sure that there is an electrical bond. Refer to Chapter 20, Electrical Bonding - Maintenance Practices.
- (4) Put the ELT antenna in position on the top surface of the fuselage.
- (5) Use the screws to attach the ELT antenna to the top surface of the fuselage.
- (6) Use Type I, Class B sealer to apply a fillet seal around the antenna where it touches the outside surface of the airplane. Refer to Chapter 20, Fuel, Pressure, Weather and High-Temperature Sealing - Maintenance Practices.
- (7) Put the master switch, on the emergency locator transmitter, in the ON position.
- (8) Do a Transmitter Test of the ARTEX C406-2 Emergency Locator Transmitter (ELT) System. Refer to Emergency Equipment - Inspection/Check.
- (9) Install the aft cargo floor panel between FS 264.00 and FS 307.91 for the 208 and FS 332.00 and FS 355.91 for the 208B.
- (10) Install the overhead panel.
- (11) Close the aft baggage compartment door.

4. ELT/NAV Interface Unit Removal/Installation

A. Remove the ELT/NAV Interface Unit (Refer to Figure 201).

- (1) Open the aft baggage compartment access door.
- (2) Disengage the ELT/NAV on the cockpit circuit breaker panel.
- (3) Remove the aft cargo floor panel between FS 264.00 and FS 307.91 for the 208 and FS 332.00 and FS 355.91 for the 208B.
- (4) Disconnect the electrical connectors (PZ118 and PZ119) from the ELT/NAV interface unit.
- (5) Remove the screws and washers that attach the ELT/NAV interface unit to the shelf assembly.
- (6) Remove the ELT/NAV interface unit from the airplane.

B. Install the ELT/NAV Interface Unit (Refer to Figure 201).

- (1) Put the ELT/NAV interface unit in position on the shelf assembly.
- (2) Use the screws and washers to attach the ELT/NAV interface unit to the support assembly.
- (3) Connect the electrical connectors (PZ118 and PZ119) to the ELT/NAV interface unit.
- (4) Engage the ELT/NAV on the cockpit circuit breaker panel.
- (5) Do a Transmitter Test of the ARTEX C406-2 Emergency Locator Transmitter (ELT) System. Refer to Emergency Equipment - Inspection/Check.
- (6) Install the aft cargo floor panel between FS 264.00 and FS 307.91 for the 208 and FS 332.00 and FS 355.91 for the 208B.
- (7) Close the aft baggage compartment door.

5. Mode S Program Module Removal/Installation

A. Remove the Mode S Program Module (Refer to Figure 201).

- (1) Open the aft baggage compartment access door.
 - (2) Remove the aft cargo floor panel between FS 264.00 and FS 307.91 for the 208 and FS 332.00 and FS 355.91 for the 208B.
 - (3) Disengage the ELT/NAV circuit breaker on the cockpit circuit breaker panel.
 - (4) Disconnect the electrical connector (PZ120) from the Mode S program module.
 - (5) Remove the screws and washers that attach the Mode S program module to the shelf assembly.
 - (6) Remove the Mode S program module from the airplane.
- B. Install the Mode S Program Module (Refer to Figure 201).
- (1) Put the Mode S program module in position on the shelf assembly.
 - (2) Use the screws and washers to attach the Mode S program module to the support assembly.
 - (3) Connect the electrical connector (PZ120) to the Mode S program module.
 - (4) Engage the ELT/NAV on the cockpit circuit breaker panel.
 - (5) Do a Transmitter Test of the ARTEX C406-2 Emergency Locator Transmitter (ELT) System. Refer to Emergency Equipment - Inspection/Check.
 - (6) Install the aft cargo floor panel between FS 264.00 and FS 307.91 for the 208 and FS 332.00 and FS 355.91 for the 208B.
 - (7) Close the aft baggage compartment access door.

Figure 201 : Sheet 1 : Artex C406-2 Emergency Locator Transmitter System Installation

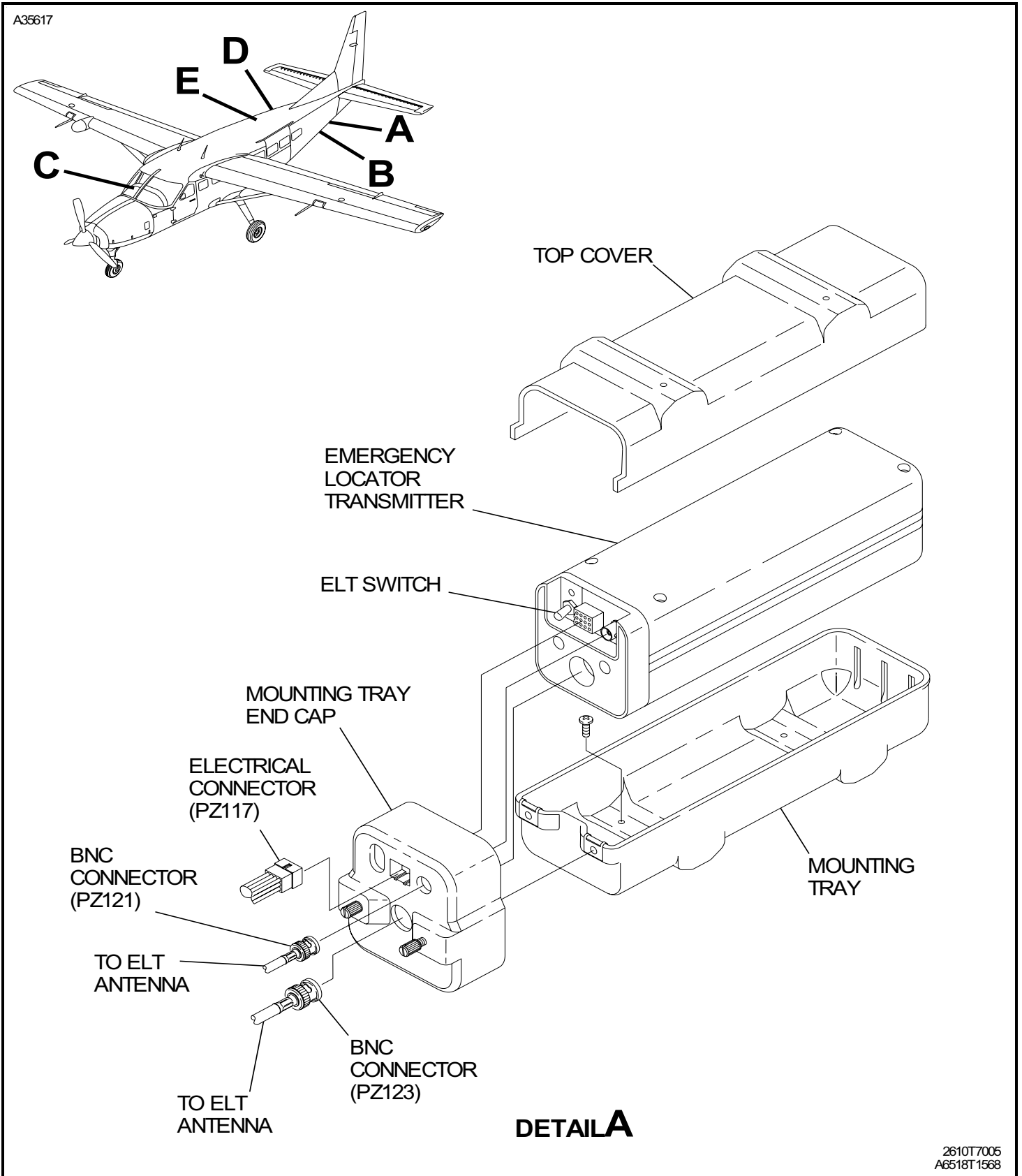
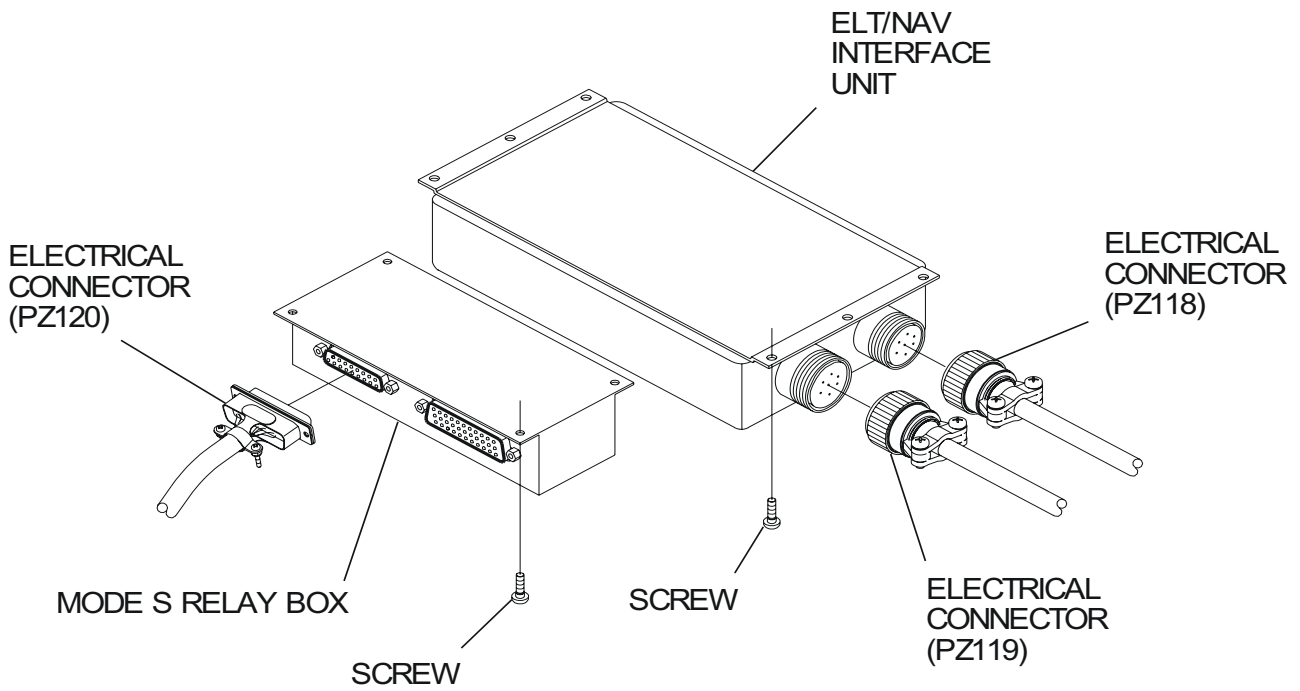

Figure 201 : Sheet 2 : Artex C406-2 Emergency Locator Transmitter System Installation

A35618



DETAIL B

26107005
A6318T1461

Figure 201 : Sheet 3 : Artex C406-2 Emergency Locator Transmitter System Installation

A35619

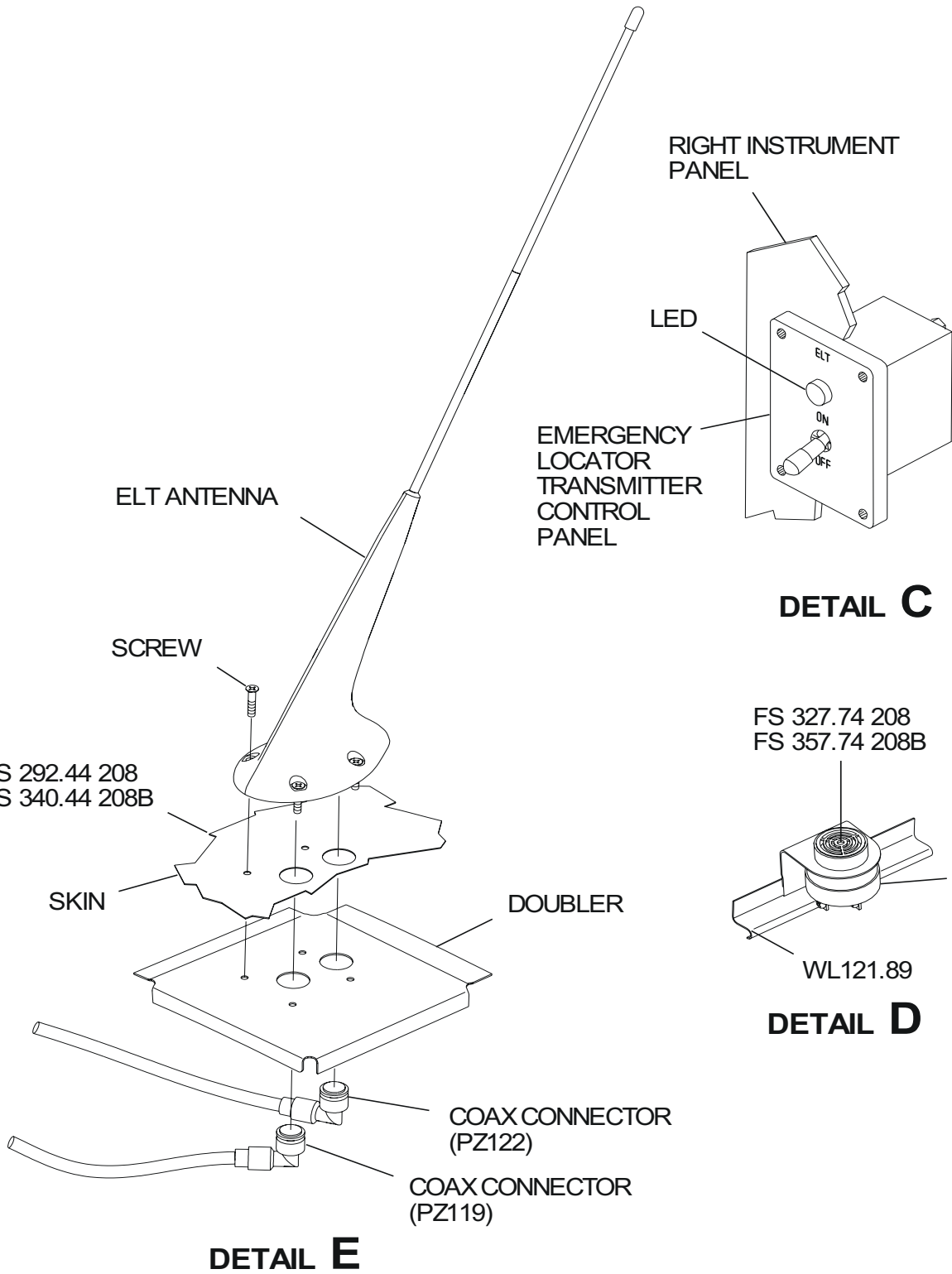

C2618T1373
D2618T1372
E2618T1372